

# Translation of the Original Operating Instructions

## PipeMAB 200/PipeMAB 525



Fig. 1

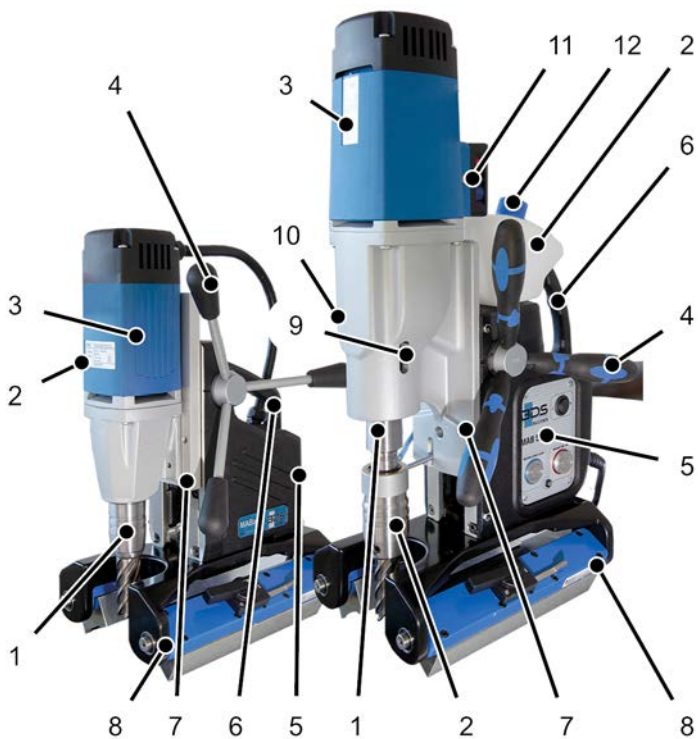

Fig. 2

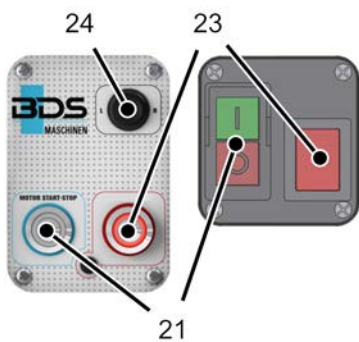

Fig. 3

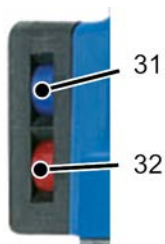
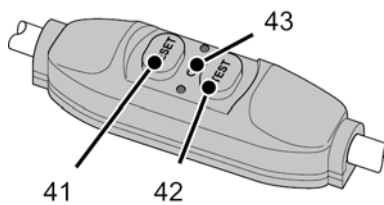

Fig. 4



## Table of contents

<b>General instructions</b> .....	<b>3</b>
<b>Safety</b> .....	<b>5</b>
<b>Components / delivery contents</b> .....	<b>11</b>
<b>Before using for the first time</b> .....	<b>12</b>
<b>Preparation</b> .....	<b>13</b>
<b>Use</b> .....	<b>18</b>
<b>Eliminating blockages</b> .....	<b>22</b>
<b>Cleaning/maintenance</b> .....	<b>23</b>
<b>Storage</b> .....	<b>24</b>
<b>Troubleshooting</b> .....	<b>24</b>
<b>Technical data</b> .....	<b>25</b>
<b>EC Declaration of Conformity</b> .....	<b>27</b>
<b>Notes</b> .....	<b>28</b>

## General instructions

### Introduction

Before using the MAB magnetic core drilling machine, hereinafter referred to as drilling machine, read the notes in these operating instructions on startup, safety, intended use as well as cleaning and care.

The links and illustrations in these instructions refer to the illustrations on the inside of the cover.

Keep these operating instructions for later user and pass them on to the next owner of the drilling machine.

### Copyright

This document is subject to copyright. Duplication or reprinting, even in part as well as reproduction of the illustrations, even if modified, is only permitted with written consent of the manufacturer.

### Liability disclaimer

All technical information, data and instructions contained these operating instructions for startup, operation and care correspond to the latest requirements at the time of printing.

The manufacturer assumes no liability for damage or injury resulting from failure to observe the operating instructions, use for other than the intended purpose, unprofessional repairs, unauthorised modifications or use of non-approved spare parts and accessories, tools and lubricants.

### Instructions on disposal



The packaging materials used can be recycled. Dispose of the packing materials no longer required according to local environmental regulations.



Do not dispose of the product in the normal household waste but instead via communal collection points.



The lubricant used can contain substances dangerous to the environment. Dispose of the lubricant according to local regulations. Pay attention to the disposal instructions from the manufacturer.

### Safety warning structure

The following warnings are used in these operating instructions:

#### DANGER

**A warning of this category indicates an impending dangerous situation.**

If the dangerous situation is not avoided, it may lead to severe injury or even death.

- ▶ Follow the instructions in this warning to avoid possible danger of serious injury or even death.

#### WARNING

**A warning of this category indicates a potentially dangerous situation.**

If the dangerous situation is not avoided, it may lead to serious injury or even death.

- ▶ Follow the instructions in this warning to avoid the danger of serious injury to persons.

#### CAUTION

**A warning of this category indicates a potentially dangerous situation.**

If the dangerous situation is not avoided, it may lead to minor or moderate injuries.

- ▶ Follow the instructions in this warning to avoid the danger of serious injury to persons.

### CAUTION

**This warning indicates potential danger to property.**

If the situation is not avoided, it may lead to material damage.

- ▶ Follow the instructions in this warning to avoid material damage.

### SAFETY INSTRUCTIONS

**Safe working during ...**

This note includes important information and instructions on safe working during the following actions.

- ▶ Follow the instructions in this warning to avoid accidents and injury.

### NOTE

A note contains additional information that is important for further processing or for simplifying the procedure step explained.

### Intended use

The drilling machine is intended solely for drilling operations in magnetic within the limits specified in the technical data.

The drilling machine is intended to be used exclusively in the commercial sector.

### Foreseeable misuse

Any use of the unit for other than the purpose prescribed in the "[Intended use](#)" section is considered as improper use and is therefore not permitted.

For example, misuse is when

- the specifications in these operating instructions are not observed
- the drilling machine is used in private households
- the drilling machine is used in a potentially explosive zone
- the drilling machine is used for processing non-approved materials such as wood, stone, concrete, non-magnetic metals ...  
(see "[Technical data](#)") for processing approved materials)
- the limits specified in the technical data are not complied with (see "[Technical data](#)")
- the drilling machine is operated in a modified or in faulty condition

### NOTE

No claims of any kind will be accepted for damage resulting from use for other than its intended purpose.

The risk is borne solely by the operator.

### Safety

#### WARNING

#### **Read all safety notes and instructions!**

Failure to comply with the following instructions may result in electric shock, fire and/or serious injury.

- ▶ Keep all safety notes and instructions for future reference.

#### NOTE

When using power tools, pay attention to the following basic safety measures to protect against electric shock, injury and fire!

## General safety instructions

### SAFETY INSTRUCTIONS

#### Working safely!

For safe handling of the drilling machine, pay attention to the general safety instructions for power tools in addition to the safety instructions listed in these operating instructions.

- ▶ The general safety instructions for power tools can be found in the separately supplied document "[Allg SiHi MAB Profi BASIC/START/PLUS](#)".
- Persons with heart pacemakers or other medical implants must not use this drilling machine.
- If necessary, a second person must help to lift the drilling machine or use suitable lifting gear.
- Before beginning work, check the condition of the safety belt.
- The drilling machine may only be repaired by a customer service authorised by the manufacturer or by the manufacturer himself.
- Do not leave the drilling machine unsupervised during operation.
- Store the drilling machine in a dry, temperate location.
- Keep the drilling machine clean, dry and free of oil and grease.
- Follow the instructions on lubricating and cooling the tool.
- Pay attention to the safety data sheets for the cooling lubricants used.
- Adhere to the local accident prevention regulations and operational safety regulations.

## Danger from electric current!

### DANGER

#### Danger to life from electric current!

Contact with live wires or components can lead to serious injury or even death! Pay attention to the following safety precautions to avoid any danger from electric current:

- ▶ Only operate the drilling machine in a dry environment.
- ▶ The machine may only be connected to an electrical connector that meets the current technical requirements and has been tested. Special attention must be paid to the safety equipment appropriate to the local conditions.
- ▶ Do not open the housing of the drilling machine. Risk of electric shock from touching live connections.
- ▶ Only use extension cables or cable drums with a cable cross-section of at least 1.5 mm<sup>2</sup> (Line type: H07RN-F3G1.5).
- ▶ Check the condition of the extension cable regularly. Replace a damaged extension cable.
- ▶ Modifications to the electrical equipment (e.g., changing the connecting plug, ...) of the drilling machine are generally prohibited.
- ▶ Work on the electrical equipment (e.g., power cord, ...) of the drilling machine may only be done by a qualified electrician of a customer service authorised by the manufacturer or by the manufacturer himself.

**⚠ WARNING****Risk of electric shock!**

Coolant/lubricant leaking from the lubricating oil tank and entering the machine could create a conductive connection to the outside of the machine if it comes into contact with live components inside the machine. This could present a risk of electric shock for the operator.

Therefore strictly observe:

- ▶ Do not overfill the cutting oil tank.
- ▶ Remove the cutting oil tank only when the shut-off valve is closed.
- ▶ Remove the cutting oil tank to fill and empty the machine.
- ▶ After using each time:  
Empty the cutting oil tank and machine completely.
- ▶ **Leaking cooling lubricant can lead to various hazards if the drilling machine is not in a vertical or overhead position.**  
Do not use the cooling lubrication device of the machine. Empty the tank completely.  
Use grease spray or cutting paste when working in a non-vertical position.

**Risk of injury!****⚠ WARNING****Improper handling of the drilling machine increases the risk of injury!**

Pay attention to the following safety notes:

- ▶ Operate the drilling machine only with the protective equipment specified in these operating instructions (see section "[Personal protective equipment](#)").
- ▶ Do not wear protective gloves when the drilling machine is running. A glove can be caught by the drilling machine and torn off the hand. Risk of losing one or more fingers.
- ▶ Remove loose jewellery before beginning work.
- ▶ Wear a hair net if you have long hair.
- ▶ Check the tool for firm seating before using each time (see section "[Inserting the tool](#)").
- ▶ Check for secure clamping of the electromagnets on the substrate before use each time (see section "[Preparation](#)").
- ▶ Always switch off the drilling machine before changing tools, doing maintenance or cleaning. Wait until the drilling machine has come to a complete standstill. Remove plug from the mains socket.
- ▶ Do not reach into the tool while it is running. Only remove swarf when the drilling machine is stationary. Wear protective gloves when removing swarf, use swarf hooks if necessary.
- ▶ Do not allow the connecting cable to hang over edges (trip wire effect).

▶ **Risk of falling when working on a ladder!**

The operator must be secured with a safety belt because the drilling machine can oscillate dangerously when the magnet is triggered.

▶ **The drilling machine could fall down if the magnet is triggered!**

Secure the drilling machine with the safety belt supplied when working from an inclined or horizontal position or during overhead work.

**⚠ WARNING**

**Risk of injury due to unintentional starting of the motor!**

Pay attention to the following safety notes to avoid danger from motor starting unintentionally:

For safe stopping of the motor:

- ▶ Switch off the motor with the "Motor" on/off switch (21).
- ▶ Switch off the drill using the main switch (23).
- ▶ Disconnect the voltage supply (pull out the mains plug).

**⚠ WARNING**

**Danger of injury from noise!**

The measured sound pressure level of the machine is > 85 dB(A). The actual sound pressure level at the place of use may vary.

For protection against injury.

- ▶ Wear ear protection.

**⚠ WARNING**

**Risk of injury from the drill core!**

The drill core produced during core drilling can cause various injuries when falling or being ejected.

For protection against injury.

- ▶ Make sure that nobody can be hit by the drill core.
- ▶ Cordon off the place of use to protect against danger to third parties.



## Preventing damage

### CAUTION

#### Potential damage to property if the drilling machine is used improperly!

Pay attention to the following notes to avoid damage to property:

- ▶ Before connecting the drilling machine, compare the connection data (voltage and frequency) on the type plate with those of your mains power supply. The data must correspond in order to avoid damage to the drilling machine.
- ▶ Always carry the drilling machine by the handle.
- ▶ Lay the connecting cable in such a way that it cannot be caught and wound up in the rotating part of the drilling machine.

### CAUTION

#### Possible material damage by using non-approved spare parts, auxiliary materials and accessories!

Pay attention to the following note to avoid damage to property:

- ▶ Only use original spare parts and operating materials and original accessories specified and approved by BDS.

## Environmental protection

### Possible environmental damage

Severe damage to the environment can result from improper handling and in particular, improper disposal of environmentally hazardous materials.

- Collect used cooling lubricants during operation by suitable means (e.g. collecting trough, ...) and dispose of them according to the locally applicable legal regulations.
- Pay attention to the product datasheets for operating/auxiliary materials.

## Safety appliances

### Personal safety switch

The drilling machine has a personal safety switch (PRCD - Portable Residual Current Device) that is integrated in the mains connecting cable. The power supply is interrupted if residual current occurs.

Check the function of the personal safety switch regularly as follows before startup.

- Set up the drilling machine in a vertical working position and switch on the Motor (21) with the on/off switch.
- Press the "TEST" (42) button.
  - ⇨ The power supply is interrupted.
  - ⇨ Tripping of the personal safety switch is shown in the function indicator (43)
- Press the "RESET" (41) button.

### Switching on again after the personal protection switch was tripped

- Eliminate the cause of the tripping of the personal protection switch.
- Press the "RESET" (41) button.

## Restart protection

### NOTE

The drilling machine stops automatically when the power supply is interrupted.

To prevent the drill from starting unexpectedly when the power supply returns (restart protection), the drill must be switched on again using the "Motor" on/off switch (21).

## Overheat protection (PipeMAB 525)



The drilling machine is also protected against overheating. If the drilling machine becomes too hot, it switches off automatically.

Carry out the following steps before continuing work with the drilling machine:

- Remove any blockages.  
(see the "[Eliminating blockages](#)" section)
- Allow the drilling machine to run at idle for approx. 2 minutes.
- ↩ The drilling machine is then ready for operation again.



## Symbols on the drilling machine

The symbols on the drilling machine have the following meaning:



Symbol	Meaning
	Electric shock hazard!
	Read the operating instructions before beginning work!
	Wear protective goggles and ear protection!

## Personal protective equipment

Wear the following protective equipment at all times when operating the drilling machine:

Symbol	Meaning
	Close-fitting work protection clothing with a low tear strength
	Goggles for protecting eyes against flying parts and liquids and ear protection in areas with noise emission >80 dB(A)
	Safety shoes for protecting feet against falling objects

Also wear the following protective equipment during special work:

Symbol	Meaning
	Helmet for protecting your head against falling objects
	Wear a harness where there is a danger of falling
	Gloves for protection against injuries

**Components / delivery contents****Machine overview**See [Fig. 1](#)**PipeMAB 200**

1	19 mm (3/4 in.) Weldon tool mount
2	Cutting oil tank (concealed)
3	Drive motor
4	Hand lever
5	Control panel (see <a href="#">Fig. 2</a> )
6	Handle
7	Machine slide and guide
8	Magnetic base (2 units)

**PipeMAB 525**

1	MK3/19 mm industrial tool holder (in MK3 spindle taper)
2	Cutting oil tank
3	Drive motor
4	Hand lever
5	Control panel (see <a href="#">Fig. 2</a> )
6	Handle
7	Machine slide and guide
8	Magnetic base (2 units)
9	Opening for ejector
10	2-speed gearbox with selector (concealed)
11	Electronic speed and torque controller (see <a href="#">Fig. 3</a> )
12	Filler neck for cutting oil

**Operating/display elements**See [Fig. 2](#)

21	Motor ON/OFF switch
23	Master switch
24	(PipeMAB 525) Direction of rotation switch

**PipeMAB 525**See [Fig. 3](#)

31	Speed setting
32	Torque setting

See [Fig. 4](#)

41	"RESET" button
42	"TEST" button
43	Function display

**PipeMAB 525**

Not illustrated

	Carbon brush wear indicator
--	-----------------------------

**Scope of supply**See [Fig. 9](#)**PipeMAB 200**

	Pipe magnetic clamping system - core drilling machine
A	Safety belt
B	ZAK 100 ejector pin
C	Hexagonal screwdriver, SW4
	Transport case (not illustrated)
	Operating instructions/guarantee card (not illustrated)

**PipeMAB 525**

	Pipe magnetic clamping system - core drilling machine
A	Safety belt
B	ZAK 100 ejector pin
C	Hexagonal screwdriver, SW5
D	Industrial tool holder ZIAL 319KN
E	MK3 ejector pin
	Transport case (not illustrated)
	Operating instructions/guarantee card (not illustrated)

**Before using for the first time****Transport inspection**

As standard, the drilling machine is supplied with the components indicated in the section "[Scope of supply](#)".

**NOTE**

Check for visible signs of damage or missing items on delivery. Report an incomplete or damaged delivery to your supplier/retailer immediately.

## Preparation

This section contains important instructions on the required preparation before beginning any work.

### Additional safety measures for certain work

#### Non-vertical work position

#### WARNING

##### **Risk of injury from a falling drilling machine.**

When working in an inclined or horizontal position or during overhead work, the drilling machine must be secured using the safety belt (A) supplied to prevent it from falling.

- ▶ Check the safety belt for correct function before using. Replace a damaged safety belt immediately.
- ▶ Attach the safety belt so that the drilling machine slips away from the operator.
- ▶ Lay the safety belt as taught as possible around the handle of the drilling machine.
- ▶ Check the secure fitting of the safety belt and lock before starting work.
- ▶ Use the protective equipment stipulated in the section "[Personal protective equipment](#)".

#### CAUTION

##### **Risk of injury from leaking cooling lubricant!**

Leaking cooling lubricant can lead to various hazards if the drilling machine is not in a vertical or overhead position.

- ▶ Do not use the cooling lubricant device of the drilling machine. Empty the tank completely.
- ▶ Use grease spray or cutting paste when working in a non-vertical position.

#### Working with the risk of falling

#### WARNING

##### **Risk of falling from sudden oscillating movements of the drilling machine.**

When starting up or when the magnet fails, the drill may perform a sudden oscillating movement. Risk of falling when working on a ladder!

- ▶ Wear a harness where there is a danger of falling.
- ▶ Secure the drilling machine with the safety belt (A) supplied.

### Check the condition of the substrate

The magnetic holding force is dependent on the condition of the substrate. The clamping force is significantly reduced by paint, zinc and scale coatings and rust.

The substrate must satisfy the following conditions in order to achieve sufficient magnetic holding force:

- The substrate must be magnetic.
- The clamping surface and the magnetic foot (8) must be clean and grease-free.
- The clamping surface must be completely smooth and level.

#### NOTE

Before using, clean the substrate and the magnetic foot (8) of the drilling machine.

Remove any unevenness and loose rust from the substrate.

Maximum possible magnetic holding force with the following material thickness (S 275 JR/SAE 1018):

Material thickness	Magnetic holding force
3 mm	410 kg
10 mm	890 kg
20 mm	1,020 kg

To assess the substrate and the optimum magnetic holding force, see chapt. "Magnetic holding force max. at material thickness (SAE 1018)" and "Magnetic base suitable for pipe diameter" in the [Technical data](#).

### Filling the cutting oil tank

#### ⚠ CAUTION

#### Risk of injury from leaking cooling lubricant!

Leaking cooling lubricant can lead to various hazards.

- ▶ Do not overfill the cutting oil tank.
  - ▶ Remove the cutting oil tank only when the shut-off valve is closed.
  - ▶ Remove the cutting oil tank to fill and empty the drilling machine.
- Close the shut-off valve below the cutting oil tank (5).
  - Pull the cutting oil tank upwards out of the drilling machine. Remove the cover of the filler neck (6) on the cutting oil tank.
  - Filling the cutting oil tank.
  - Close the lid of the filler neck and put it back on the mounting of the drilling machine from above.
  - Opening the shut-off valve.

#### NOTE

To ventilate the cutting oil tank, open and close the lid of the filler neck briefly as required.

## Inserting the tool

### Special notes

#### WARNING

#### Risk of injury!

Pay attention to the following instructions to avoid injury.

- ▶ Do not use damaged, soiled or worn tools.
- ▶ Change tools only when the drilling machine is switched off and at a standstill. Pull the plug out of the mains socket.
- ▶ After inserting, check that the tool is firmly seated.
- ▶ Only use tools, adapter and accessories that match the drilling machine.
- ▶ Allow hot tools to cool down before changing.
- ▶ PipeMAB 525: Never look for the correct position for the ejector by tapping the motor switch.

- The PipeMAB 200 drilling machine is equipped with direct mounting.
- The PipeMAB 525 drilling machine is equipped with an MK3 spindle taper, which is fitted with an industrial holder on the delivery side.

Depending on the type of tool to be used, corresponding drill chucks, quick-clamping systems or adapters must be used.

### PipeMAB 200

Tool with:	Tool holder to be used
19 mm Weldon shaft	Insert into the fixed direct mounting (1).

### PipeMAB 525

Tool with:	Tool holder to be used
MK3 cone	Insert directly into the spindle taper.
MK2 cone	Use a MK3:2 adapter sleeve and insert directly into the spindle taper (available as accessory).
19 mm Weldon shaft	Use a 19 mm (1) MK3/Weldon industrial tool holder.
Straight shank	Use key-type drill chuck with tapered mandrel MK3/B16 (available as accessory).
Thread taps	Use industrial tool holder with Weldon Shank and matching ZGA adapter for thread taps (available as accessory).

### Insert the core drill into the direct mounting PipeMAB 200

#### Insert tool (see [Fig. 5](#))

- Loosen both hexagon socket screws of the direct mounting (1) with the hexagon socket screwdriver (C) supplied.
- Insert the core drill into the direct mounting.

#### NOTE

Insert the appropriate ejector pin before inserting the core drill.

- Tighten both hexagon socket screws for the direct mounting (1) with the hexagon socket screwdriver (C) supplied.

#### Removing the tool

- Loosen both hexagon socket screws of the direct mounting (1) with the hexagon socket screwdriver (C) supplied and take the core drill out from below.

### Weldon industrial tool holder PipeMAB 525

#### Insert tool (see [Fig. 5](#))

- Insert the 19 mm MK3/Weldon industrial tool holder (1) into the spindle taper of the machine.

#### NOTE

When using tools/adapters with MK2 taper, use MK 3:2 adapter sleeve.

- Before inserting, clean the Weldon shank of the tool and the tool holder.
- Loosen both hexagonal socket screws in the tool holder using the hexagonal screwdriver (C) supplied.
- Insert the tool into the tool holder from below.

#### NOTE

Insert the appropriate ejector pin (B) before inserting a core drill.

- Tighten both hexagonal socket screws in the tool holder using the hexagonal screwdriver supplied.

#### Removing the tool

- Loosen both hexagonal socket screws in the tool mount using the hexagonal screwdriver supplied and remove the tool from below.

#### Remove the industrial tool holder:

- Turn the industrial tool holder until the ejector slips into the opening for the ejector (9).
- Lever out the industrial tool holder with the ejector or loosen it by tapping against the ejector.



## Using a gear rim drill chuck PipeMAB 525

### WARNING

#### Risk of injury!

An insufficiently secured tool can lead to serious injuries.

- ▶ Tighten the drill chuck only with the chuck key provided.
- ▶ Always remove the chuck key from the drill chuck after tightening or loosening.

### NOTE

- ▶ Use drill chuck with MK3 taper. When using tools/adapters with MK2 taper, use MK3:2 adapter sleeve.

### Inserting the drill chuck

- Push the gear rim drill chuck onto the tapered mandrel and insert the combination into the spindle taper of the drilling machine.
- Open the drill chuck and insert the tool into the drill chuck.
- Close the drill chuck by hand and then tighten it with the chuck key.

### Removing the drill chuck

- Open the drill chuck with the chuck key and remove the tool.
- Turn the drill chuck until the ejector slips into the opening for the ejector (9).
- Lever out the drill chuck with the ejector or loosen the drill chuck by tapping against the ejector.

## Adapter for thread taps PipeMAB 525

### Insert tool (see Fig. 6)

- Insert the industrial tool holder with Weldon shank into the spindle taper of the drilling machine.
- Insert the thread tap into the adapter for thread taps.
- Insert the adapter with thread tap into the industrial tool holder.
- Tighten both hexagonal socket screws in the tool holder and fix the adapter.

### Removing the tool

- Loosen both hexagonal socket screws in the industrial tool holder and remove the adapter for the thread tap from below.
- Remove the thread tap by pulling downwards out of its adapter.

## Use

### Activating/deactivating the magnetic clamp

(see [Fig. 8](#))

#### Activating the magnetic clamp

- Secure the drilling machine at the handle (6) to prevent it from slipping.
- Switch on the first magnet.  
To do this, switch on the magnet actuating lever (61) of the magnetic clamp. The magnetic actuating lever engages in a lock in the switch-on position (marked "max.").
- Switch on the second magnet.  
To do this, switch on the magnet actuating lever (61) of the magnetic clamp. The magnetic actuating lever engages in a lock in the switch-on position (marked "max.").
- Check that the drill is firmly seated by the magnetic holding force.

#### NOTE

The maximum magnetic holding force depends on the material thickness of the contact surface (see [Technical data](#)).

See example illustration for placing on a pipe (R) (see [Fig. 7](#)).

#### Deactivating the magnetic clamp

- Secure the drilling machine at the handle (6) to prevent it from slipping.
- Switch off the first magnet.  
Actuate locking lever (62) and reset magnet operating lever (61).
- Switch off the second magnet.  
Actuate locking lever (62) and reset magnet operating lever (61).

### Switching the drilling machine on/off.

- Switch the drilling machine on or off using the main switch (21).
- Switch the drive motor on or off with using the on/off switch (21).

#### NOTE

The drive motor can only be switched on if the drilling machine has been switched on at the main switch beforehand.

Allow a severely overheated drilling machine to run on at idle speed for approx. 2 minutes to cool it down.

The drilling machine switches off automatically in the event of a power failure or if the main switch is deactivated.

### Selecting the speed range (PipeMAB 525)

The drilling machine has a gearbox with two mechanical gear stages: The gear stage is set with the selector levers (16).

#### CAUTION

#### Damage to equipment!

Switching the gearbox during a rotary movement could cause damage.

- ▶ Switch the gear stages only when the drilling machine is at a standstill.

#### NOTE

Select the speed range according to the material and drilling diameter.

- ↻ To preselect the gear stage, set the selection lever (16) to the desired speed range when the drilling machine is switched off according to the following table.

Gear stage	Max. load speed	Selector lever
Step 1	280 rpm	•
Step 2	585 rpm	••

### Setting the speed PipeMAB 525

#### ⚠ CAUTION

#### Outward spinning parts!

Improperly set parameters can break the tool.

- ▶ Operate the drilling machine only with the parameter permitted for the tool.

In addition to the mechanical gearbox, the drilling machine is also equipped with full-wave control electronics for stepless variable speed adjustment.

- ↻ First set the appropriate gear stage, then adapt the speed using the electronic speed control (7).

Gear stage	Speed range
Step 1	70 - 280 rpm
Step 2	180 - 580 rpm

### Setting the torque cut-off (PipeMAB 525)

#### ⚠ CAUTION

#### Outward spinning parts!

Improperly set parameters can break the tool.

- ▶ Operate the drilling machine only with the parameters permitted for the tool.
- ▶ Do not use the drilling machine cut-off via the "torque cut-off" function when cutting blind hole threads.

In order to protect the tool, set the maximum torque of the drilling machine (see [Fig. 3](#))

- Set the torque control (32) to the maximum desired torque.
- ↔ The drilling machine switches off when it reaches the maximum set torque.

#### NOTE

The drilling machine switches off when it reaches the maximum set torque. After switching off, the drilling machine must be switched off and on again using the ON/OFF switch (21).

### Drilling with the drilling machine

#### Drilling with twist drills

#### NOTE

Under excessive pressure, the drilling machine can wear out. The drilling machine can be overloaded.

Make sure that swarf is removed regularly. With larger drilling depths, break up the swarf.

#### NOTE

When working overhead, use the high-performance grease spray ZHS 400 or ZHS 550/570 cutting paste. Spray the drill before drilling or apply cutting paste. In the case of larger drill depths, repeat this procedure.

#### PipeMAB 200

#### NOTE

BDS offers twist drills with Weldon shank for direct mounting of the PipeMAB 200.

#### PipeMAB 525

- Insert the spiral drill with MK taper directly into the spindle taper (2) of the drilling machine from below.
- Insert twist drills with straight shank into the gear rim drill chuck after fitting the drill chuck (see section "[Using a gear rim drill chuck PipeMAB 525](#)").
- Position and fix the drilling machine at the location of use.
- Activate the clamping magnet and check the magnetic holding force (see section "[Activating/deactivating the magnetic clamp](#)").
- Select a suitable speed and switch the drilling machine on.
- Guide the drilling machine to the material with the hand lever (14).

## Drilling with core drills

### NOTE

Drilling with core drills does not require great force. The drilling process is not accelerated by higher pressure. The drill wears faster and drilling machine can be overloaded.

Make sure that swarf is removed regularly. With larger drilling depths, break up the swarf.

Use the high-performance BDS 5000 cutting oil in the cooling lubricant system of the drilling machine.

### NOTE

The cooling lubricant system may be used when working overhead. In this case, use the high-performance ZHS 400 grease spray or ZHS 550/570 cutting paste. Spray the drill on the inside and outside before drilling or apply cutting paste. In the case of larger drill depths, repeat this procedure.

## PipeMAB 200

- Insert the corresponding ejector pin into the core drill.
- Insert the core drill into the direct mounting (1) (see section "[Insert the core drill into the direct mounting PipeMAB 200](#)").
- Position and fix the drilling machine at the location of use.
- Activate the clamping magnet and check the magnetic holding force (see section "[Activating/deactivating the magnetic clamp](#)").
- Switch the drilling machine on (see section "[Switching the drilling machine on/off](#)").
- Guide the drill to the material with the hand lever (4).

## PipeMAB 525

- For core drills with:
  - Mount the 19 mm Weldon shaft onto the industrial tool holder (1).
- Connect the cooling lubricant device.
- Insert the corresponding ejector pin into the core drill.
- Insert the core drill into the tool mount.
- Position and fix the drilling machine at the location of use.
- Activate the clamping magnet and check the magnetic holding force (see section "[Activating/deactivating the magnetic clamp](#)").
- Select a suitable speed and switch the drilling machine on.
- Guide the drill to the material with the hand lever (4).

### Cutting threads (PipeMAB 525)

The drilling machine is equipped with reversible direction of rotation and can also be used for cutting threads.

Proceed as follows for cutting threads:

- Drill a hole for the thread.
- Switch the drilling machine off and set the lowest gear stage and speed.
- Set the direction of rotation on the switch (24) to clockwise (R).
- Tighten the thread tap in the drilling machine using the appropriate thread tap adapter.
- Switch the drilling machine on position the tap drill at the hole.
- Move the machine slide on the hand lever (14) without exerting pressure until the desired thread length has been cut.
- Switch the drilling machine off and set the rotation on the switch (24) to anti-clockwise (L).
- Switch the drilling machine on again and withdraw the tap drill out of the workpiece completely. Then use the hand lever (14) to guide the machine slide upwards in order to avoid damaging the top of the thread.

### Reaming/counter-sinking (PipeMAB 525)

Thanks to its wide range of operating speeds, the drilling machine can also be used for reaming or counter-sinking.

#### CAUTION

##### Damage to equipment!

Overloading leads to damage.

- ▶ When reaming and counter-sinking, observe the limits stated in the technical data for the tools to be used.

## Eliminating blockages

### ⚠ WARNING

#### Risk of injury!

Danger of cut injuries from broken tool parts or swarf.

- ▶ Put protective gloves on before starting work.

#### Blockages caused by a broken tool:

- Switch the drilling machine off and remove plug from the mains socket.
- Move the machine slide to the upper position with the help of the hand lever (11).
- Replace defective tool.
- Remove swarf.

#### Other blockages:

- Switch the drilling machine off at the motor switch.
- Move the machine slide to the upper position with the help of the hand lever (11).
- Remove swarf and check tool.

#### NOTE

The BDS range of accessories includes special devices (e. g., POW 200) for removing swarf.

## Cleaning/maintenance

### ⚠ WARNING

#### Risk of injury!

Unqualified cleaning/maintenance can lead to considerable danger for the user.

- ▶ Switch the drilling machine off and remove plug from the mains socket before any maintenance and cleaning.
- ▶ When using compressed air for cleaning, wear protective goggles and gloves.
- ▶ Protect other persons in the work area.

### CAUTION

#### Damage to property!

Damage by penetrating liquids.

- ▶ Never immerse the drilling machine in water or other liquids.

## Cleaning

### After each use

- ↻ Remove the inserted tool.
- ↻ Remove swarf and coolant residues.
- ↻ Empty the cutting oil tank and drilling machine completely. To do this, remove the container as described in section "[Filling the cutting oil tank](#)" and fill the coolant from the filler neck into a suitable container.
- ↻ Clean the tool and the tool holder on the drilling machine.
- ↻ Clean the guide of the machine slide.
- ↻ Pack the drilling machine and accessories back into the transport case.

## Maintenance

### ⚠ WARNING

#### Danger caused by unqualified repairs!

Unqualified repairs can lead to considerable danger for the user and cause damage to the drilling machine.

- ▶ The drilling machine may only be repaired by a customer service authorised by the manufacturer or by the manufacturer himself.
- ▶ Work on the electrical equipment (e.g., power cord, ...) of the drilling machine may only be done by a qualified electrician of a customer service authorised by the manufacturer or by the manufacturer himself.

### Adjusting the machine slide guide

If the machine slide guide (14) exhibits too much clearance, it must be adjusted. For this purpose, proceed as follows:

- ↻ Loosen the clamping bolts.
- ↻ Tighten the adjusting screws evenly.
- ↻ Tighten the clamping screws again.

### Replacing the carbon brushes

Replacement of the carbon brushes may only be carried out by BDS or by an authorised specialist workshop. Unauthorised repairs will invalidate the guarantee.

**Check hoses**

Hose lines are subject to ageing and wear. Therefore, do regular visual inspections and replace old or worn hose lines if necessary.

**Check the safety belt**

Check the safety belt for damage before using each time. Render a damaged safety belt immediately unusable and replace it with a new safety belt.

**Customer service/service**

Should you have any questions on customer service/service, please contact BDS. We will be happy to give you the address of your nearest service partner.

**Storage**

When storing the drilling machine for a longer period of time, clean as described in section "[Cleaning](#)". Store the drilling machine and all its accessories in the transport case at a dry, clean and frost-free location.

**Troubleshooting**

<b>Error</b>	<b>Possible cause</b>	<b>Remedy</b>
The motor does not start after pressing the ON/OFF switch or stops during operation.	Plug not inserted in the socket.	Insert plug.
	Circuit breaker switched off.	Switch on circuit breaker.
	Direction of rotation not selected. (PipeMAB 525)	Select direction of rotation.
	The internal safety switch has switched the drilling machine off due to overheating. (PipeMAB 525)	Allow the drilling machine to cool down.
	The torque cut-off has tripped. (PipeMAB 525)	Switch the drilling machine off and on again.
The circuit breaker in the power distributor trips.	Too many appliances connected to the same power circuit.	Reduce the number of appliances on the power circuit.
	Drilling machine is defective.	Contact customer service.
The lubrication system does not function.	No lubricant available.	Top up the lubricant.
	Lubricant tap closed.	Open the lubricant tap.
	Connecting nipple clogged.	Clean the tank and nipple.

**NOTE**

If you cannot resolve the problem with the steps described above, please contact customer service.



## Technical data

Model	PipeMAB 200	PipeMAB 525	
Dimensions (L x W x H)	266 x 191 x 350 - 510	266 x 191 x 525 - 685	mm
Magnetic foot (L x W)	221 x 48 (2 units)		mm
Max. magnetic holding force with material thickness (S 275 JR/SAE 1018)			
- 3 mm	410		kg
- 10 mm	890		kg
- 20 mm	1020		kg
Magnetic foot suitable for pipe diameter:	> 85		mm
Approx. net weight	16	19.5	kg
Operating voltage (see type plate)	230 V / 50-60 Hz and/or 110-125 / 50-60 Hz		
Power consumption	1050	1,600	W
Connecting			
- Standard equipment	Safety plug type F - CEE 7/4, 16 A		
- Special version	Standard mains plug in the national version of the country of use		
Stroke	160	160	mm
Core drill:			
- long Ø	12 - 32	12 - 50	mm
Cutting depth max.	40	40	mm
Twist drill:			
- max. Ø	13	20	mm
Thread max. Ø	-	M20	
Reaming max. Ø	-	20	mm
Counter-sinking max. Ø	-	50	mm
Rotating speed	n <sub>0</sub> = 600 n = 450	- -	rpm rpm
Speed stage 1	-	n <sub>0</sub> = 70 – 280	rpm
Speed stage 2	-	n <sub>0</sub> = 180 – 580	rpm
Thermal protection	No	Yes	
Slip clutch	No	No	
Full-wave control electronics	No	Yes	
Variable torque	No	Yes	
Clockwise/anticlockwise rotation	No	Yes	
Spindle taper	No	MK3	
Core drill assembly	Weldon 19 mm (3/4")	MK3/19 mm industrial tool holder	

Model	PipeMAB 200	PipeMAB 525	
Connecting cable length	4		m
Protection class	I		
Degree of protection	IP20		
Magnetic materials approved for machining	Ferrous metals (ferromagnetic metals)		

### Emissions

Model	PipeMAB 200	PipeMAB 525	
Noise measuring			
Noise level (Lpa)	79	86	dB
- Uncertainty (Kpa)	3	3	dB
- Sound power level (Lwa)	90	96	dB
- Uncertainty (Kwa)	3	3	dB
Vibration	< 2.5	< 2.5	m/s <sup>2</sup>

### NOTE

The total declared vibration value and the declared noise emission value have been measured according to a standardised test procedure and can be used to compare one power tool with another.

The specified total vibration value and the specified noise emission value can also be used for a preliminary assessment of the load.

### WARNING

#### Risk of injury!

Risk of injury from the emissions emanating from the machine.

- ▶ The vibration and noise emissions during actual use of the power tool may differ from the specified values, depending on the way the power tool is used, in particular the type of workpiece being processed; and
- ▶ lead to the need to establish safety measures for protecting the operator, based on an estimation of the vibration exposure during the actual conditions of use (taking into account all parts of the operating cycle, such as periods when the power tool is switched off and periods when it is switched on but running without load).

## EC Declaration of Conformity

**in accordance with Machine Directive 2006/42/EC, appendix II 1A**

Name/address of the manufacturer:	<b>BDS Maschinen GmbH</b> Martinstraße 108 D-41063 Mönchengladbach
-----------------------------------	--

We hereby declare that the product:

Model:	<b>Pipe magnetic clamping system - core drilling machine</b>
Model	<b>PipeMAB 200/PipeMAB 525</b>

conforms to the following relevant regulations:

- **EC Directive 2006/42/EC on machinery**

The following harmonised standards were applied in whole or in part:

- DIN EN ISO 12100:2011-03
- DIN EN 62841-1:2016-07

Authorised person for compiling the technical documentation:	<b>BDS Maschinen GmbH</b>
--	---------------------------

Full technical documentation is available.

The operating instructions associated with the product is available.

It is required that the product is only operated as intended. Information on operating as intended can be obtained from the technical documentation.

Mönchengladbach, 4 January 2021



Wolfgang Schroeder, Technical Director  
(Legally binding signature of the issuer)

Notes

Fig. 5



Fig. 6



Fig. 7

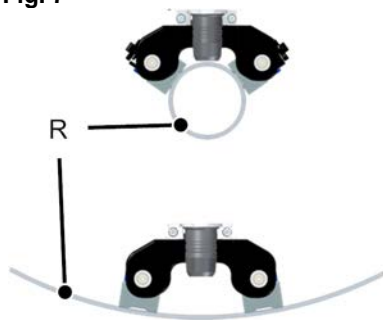

Fig. 8

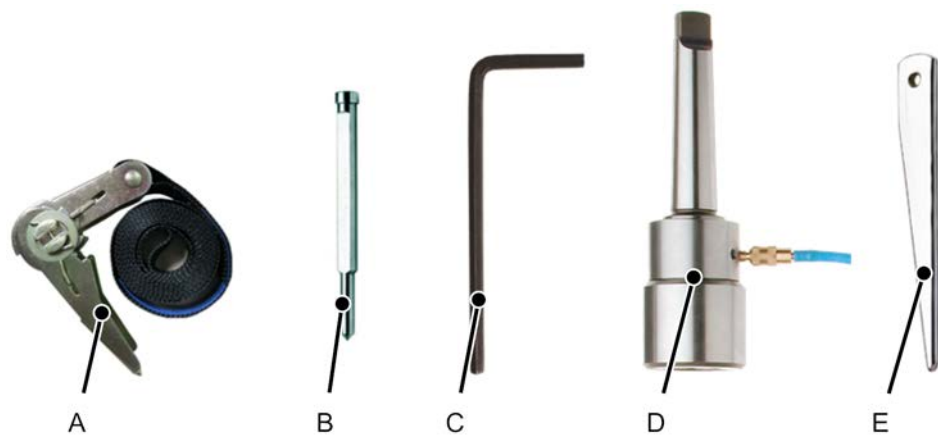

Fig. 9

## **BDS Maschinen GmbH**

Address: Martinstraße 108  
D-41063 Mönchengladbach

Telephone: +49 (0) 2161 / 3546-0

Telefax: +49 (0) 2161 / 3546-90

Email: [info@bds-maschinen.de](mailto:info@bds-maschinen.de)

Web: [www.bds-maschinen.de](http://www.bds-maschinen.de)